

ITEM NO.	PART NUMBER	DESCRIPTION	QTY.
1	VN182498	ANTENNA PLATE	1
2	91423A240	M20 X 1.5 HEX NUT	1

- NOTES:
 1) WELD HEX NUT TO PLATE
 2) BLACK TEXTURE POWDER COAT
 3) BAG INDIVIDUAL PARTS WITH LABEL ON BAG "VN182500"

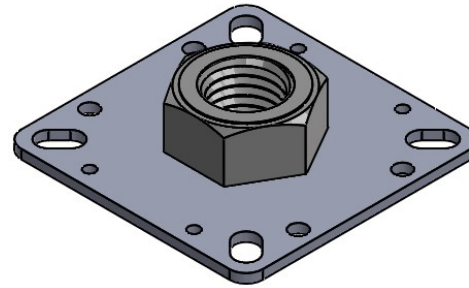
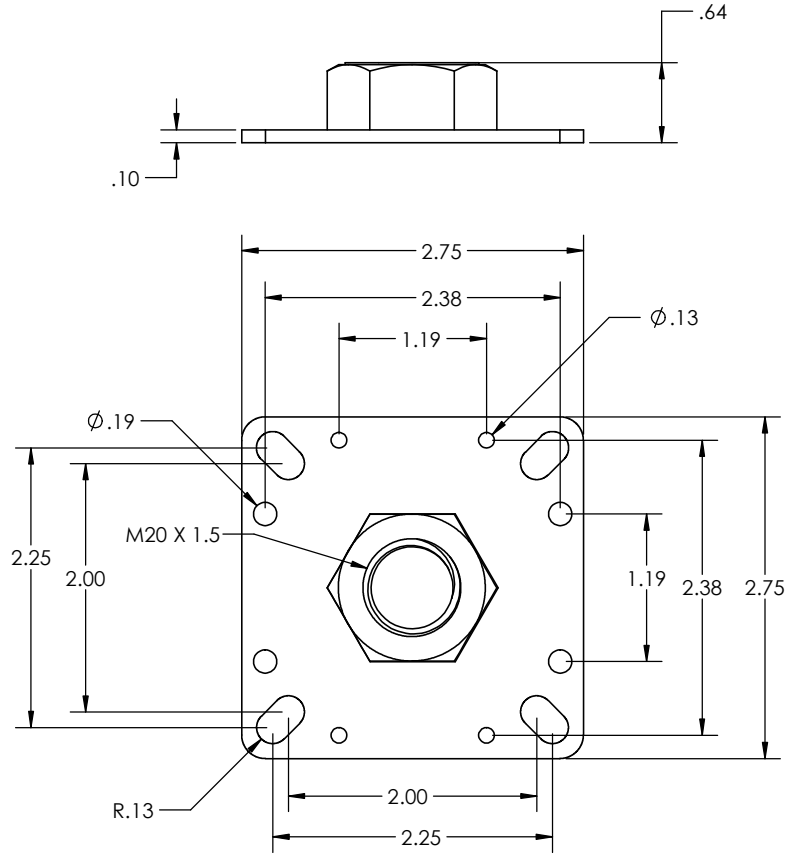

SKU:

CONFIDENTIAL AND PROPRIETARY
 THE INFORMATION CONTAINED HEREIN IS THE CONFIDENTIAL AND THE EXCLUSIVE PROPERTY OF TESSCO TECHNOLOGIES INCORPORATED. THIS DOCUMENT, AND THE INFORMATION CONTAINED HEREIN, SHALL NOT BE COPIED, REPRODUCED, PUBLISHED, DISPLAYED OR DISTRIBUTED, IN WHOLE OR IN PART, IN ANY MEDIUM, BY ANY MEANS, FOR ANY PURPOSE WITHOUT THE EXPRESS WRITTEN CONSENT OF TESSCO TECHNOLOGIES INCORPORATED.
 ©2010 TESSCO TECHNOLOGIES INCORPORATED
 ALL RIGHTS RESERVED

UNLESS OTHERWISE SPECIFIED:		DRAWN	OrtelT	Nov 08, 2019
TOLERANCES: $\pm .XX = \pm$ $\pm .XXX = \pm$ $\pm .XXXX = \pm$ $\pm .X^* = \pm$		RESP ENG		
CAD FEATURES ARE BASIC: $\square .005 A B C$ DIMENSIONS ARE IN INCHES DIMENSIONS IN [] ARE IN MM INTERPRET GEOMETRIC TOLERANCING PER ANSI Y14.5 - 2009		APPR.		
3RD ANGLE PROJECTION		MATERIAL:	STEEL	
		FINISH:	BLACK TEXTURE POWDER COAT	
		SIZE	CAGE CODE	
		B	8J168	
		DWG. NO.		REV
		VN182500		0
		DO NOT SCALE DRAWING	SCALE: 1:1	SHEET 1 OF 1

ventev

A Division of Tesco Technologies Incorporated

TITLE:
ANTENNA PLATE ASSY